

Technical Data BA37IS

Performances

		A7W35*	A2W35*	A-7W35**	A-15W35***	A7W55*
Heating Capacity	kW	11.46	8.83	8.71	8.24	10.34
Cooling Capacity	kW	9.32	6.75	5.98	5.15	7.28
Power In	kW	2.43	2.38	3.23	3.59	3.37
COP	-	4.71	3.71	2.70	2.30	3.07
Operating Current	A	6.8	6.7	8.1	8.7	8.3

Compressor

Type	BLDC Inverter	
Speed	20-100	1/s
Charge oil FVC68D	0.95	l
LRC	-	A
Max. Op. Current	16	A

Evaporator

Type	Coil	
Material	Al/Cu	
Heat Transfer Area	42	m ²
Fin Spacing	2	mm
Max Overpressure	4.2	Mpa
Air Flow	max.6000	m ³ /h
Fan Motor	max. 0,2	kW
Fan Diameter	2x450	mm
Speed	max.690	1/min
Sound Power Level	65	dB"A"
Defrost	reverse cycle	

Condenser

Type	PHE	
Material	AISI316	
Water Flow	0.55	kg/s
Minimum flow	0.30	kg/s
Temp. Difference	5	K
Water volume	10.9	l
Max. Water Overp.	250	kPa
Max. Ref. Overp.	4.2	MPa
Pump Ext. Head	5.0	m
Pump Motor	130	W

Refrigerant Circuit

Refrigerant	R410a	
Charge	4.5	kg

Aux. Heater

Heating Capacity	6	kW
------------------	---	----

Controls

Controller	pCO5	
EEV	Yes	
Water Probe	Yes	
Mixing Probe	Yes, 2x	
HW Probe	Yes	
Outdoor Probe	Yes	
Weather Comp.	Yes	
Refrigerant	2xPT	

Power Supply

Voltage	3x400	V
Frekvence	50	Hz
Max. Current C (H)	20	A

Dimensions and Connections

Heating, HW	1, 1/2	"OD
Vapour/Liquid	22/12	mm
He x Wi x De Ind.	120x53x72	cm
He x Wi x De Out.	165x82x53	cm
Weight Ind./Oud.	165/70	kg

Operating Limits

Water Overpressure	0.25	MPa
Ref. Overpressure	4.2	MPa
Air Min/Max	-15/+40	°C
Water Min/Max	20/60	°C

A2W35, acc. to EN14511, condenser dT=5K

"A2" Air Inlet +2°C

"W35" Water Outlet 35°C

Defrost energy considered.

Performance Tolerance EN14511

* at 60rps, ** at 80rps, *** at 90rps

Technical Data BA37IS

Performance *

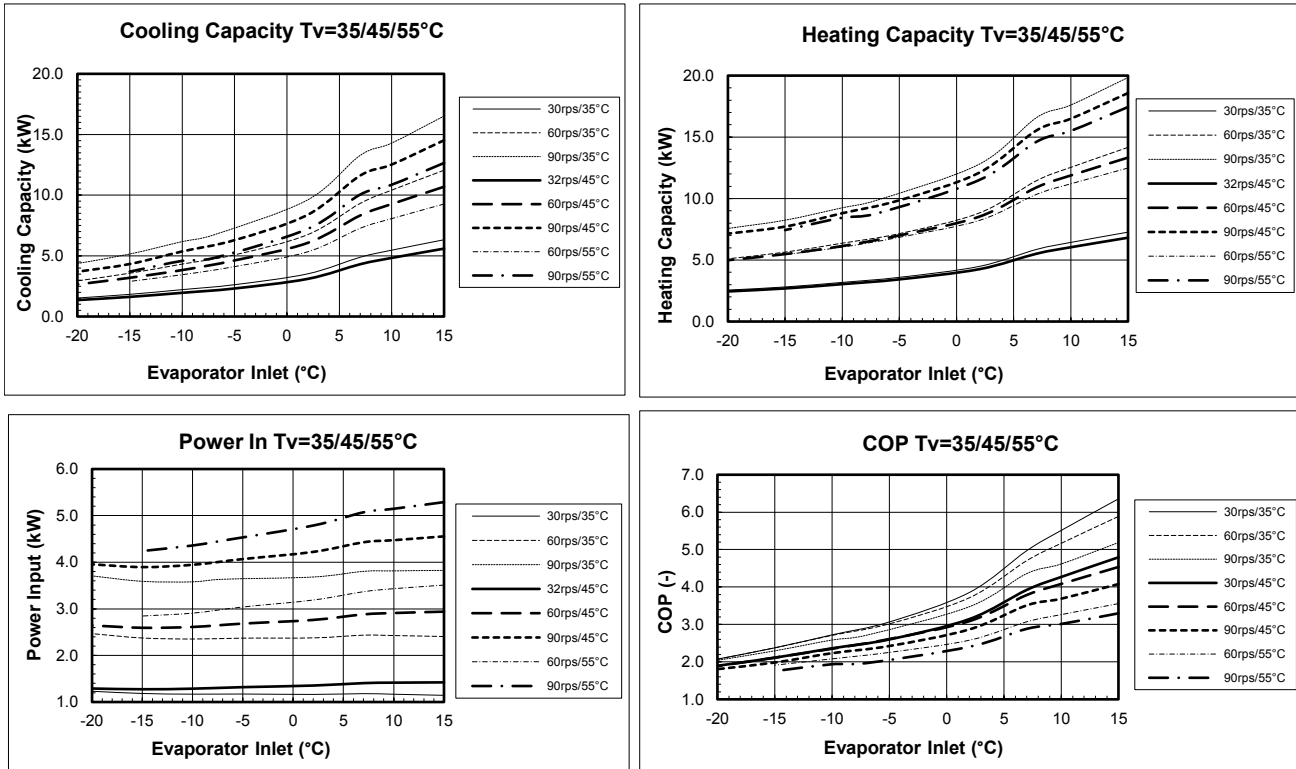

* Performance Tolerance $\pm 10\%$, defrost energy included

Dimensions, Connections 5 1 2 3 4 5

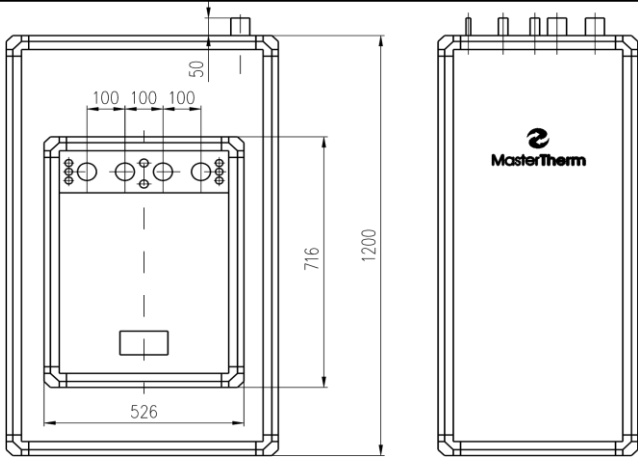

1. Liquid Line 8mm
2. Vapour Line 15mm
3. Heating Outlet 1" OD
4. Heating Inlet 1" OD
5. Electrical Bushings 2xPG29

