

AquaMaster 90 Inverter P

2-compressor ground source heat pump

Efficient and powerful ground-to-water heat pump with an output of up to 70 kW. Possibility of cascades with total power of more than 1100 kW.

Designed for heating and cooling

Suitable for industrial applications and waste heat recovery systems (industrial processes, kitchens etc.).

Safety first

With integral R290 leak detector and automatic shut down of the unit. Ventilation box as factory equipment.

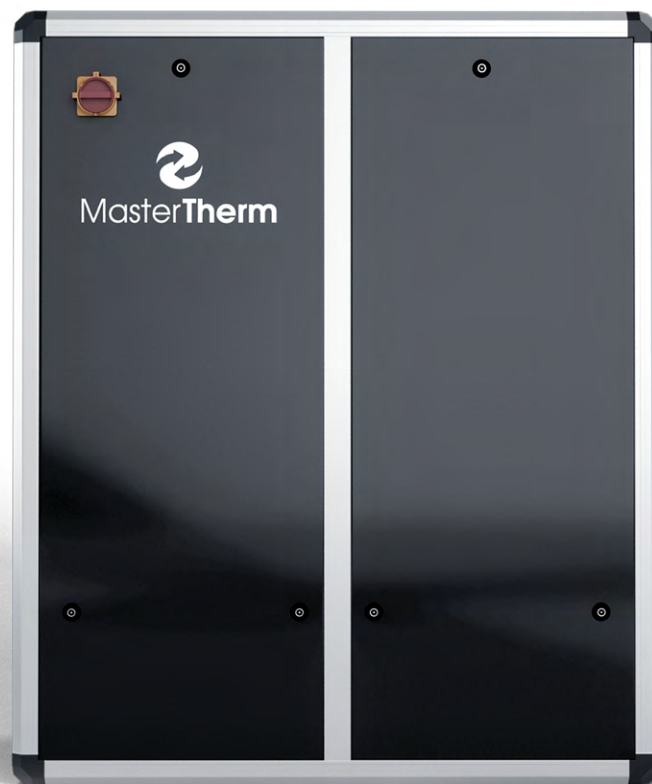

Cascade of up to 16 units

Perfect solution also for large-scale buildings. Easily connected in cascade, providing exceptional overall performance.



Ready for industrial applications



Czech (EU) product



Heating water temperature up to 75 °C



Output up to 70 kW



Online control

KEY FEATURES

- Compact ground-to-water heat pump for residential, commercial and industrial applications with R290 refrigerant
- **Power up to 70 kW (B0W35)**
- **Total cascade power of 1100 kW**



- Use for heating and cooling of the building including SHW preparation
- **Excellent also for industrial cooling and waste heat recovery**
- Extensive intelligent optional equipment: internet connection (monitoring and logging), modbus/BMS, integrated MID electric meter or heat meter, communication with PV Inverter and Batteries, smart grid etc.
- Passive cooling module (optional equipment)



• Ventilation box as recommended optional equipment

- Integrated circulation pumps for primary and secondary circuit incl. a 3-way valve



• Max heating water temperature 75 °C

- Anti-legionella function from compressor only. No backup heater required





Model	Performance at B0W35	Heat loss of the object Q_z	Seasonal energy efficiency of heating at a 35 °C low temperature operation		Seasonal energy efficiency of heating at a 55 °C medium temperature operation		Maximum heating	Order number
	kW		SCOP	Class	SCOP	Class		
AquaMaster Inverter 90IP	10-70	up to 70	TBA	TBA	TBA	TBA	75	AQ90IP-311U
Designed for								multiple-circuit heating systems
Main heating circuit								yes
Auxiliary heating circuit								independently 2 incl. mixing
Space temperature								in 2 zones
Hot water treatment								yes
Option								up to 6 heating circuits

Find more at www.mastertherm.eu

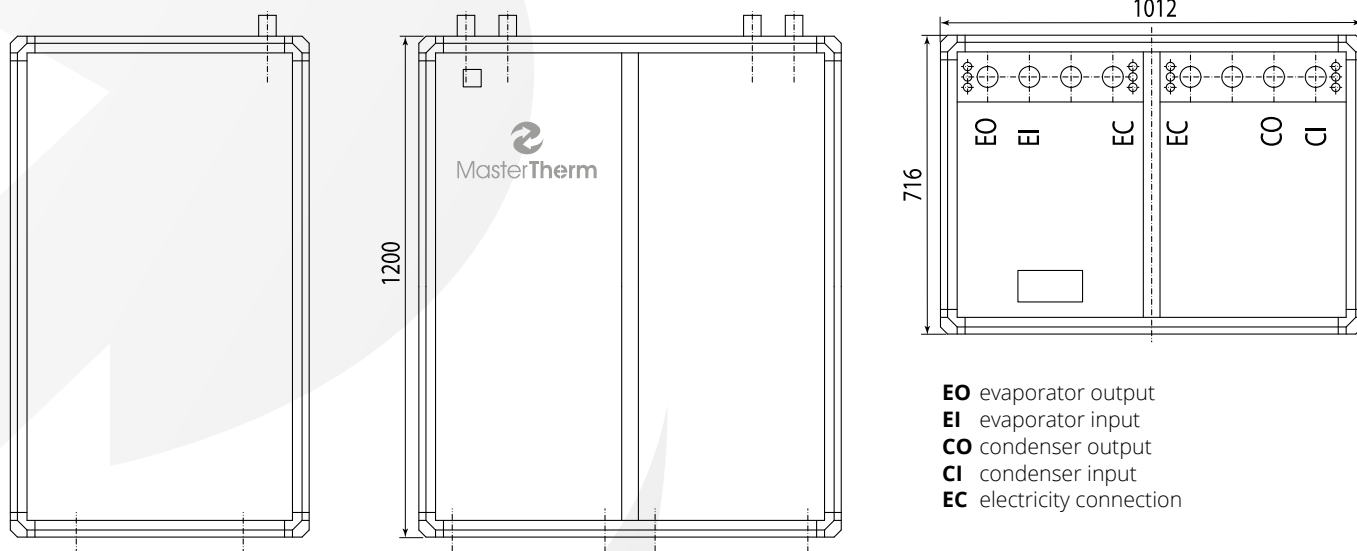

Unique Master Therm software for pump control

- Custom application for controlling the cooling circuit and peripherals
- Equithermal MaR (measurement and regulation) system
- Advanced **feedback control of building temperature** based on internal room temperature sensors
- Control via touchscreen terminal or online application
- Includes **remote service monitoring** and diagnostics
- Control of up to 6 heating circuits, including the possibility of connecting a pool or solar panel
- Cooperation with photovoltaics: **in-built connection to PV inverter**
- Smart tariff & Smart Grid: **automatic optimization of heat pump's operation based on future spot electricity prices**

